

Courtesy of Terex



STINGER 3470 | Boom Truck Crane

BOOM TRUCK CRANE STINGER 3470



FEATURES

- ▶ 34,000 lb (15 422 kg) maximum lifting capacity
- ▶ 80' (24.38 m) maximum sheave height
- ▶ 120' (36.57 m) maximum sheave height with 24-40' (7.31-12.19 m) jib
- ▶ 27-70' (82.30-21.34 m) three-section full power fully synchronized boom
- ▶ Exclusive color coded boom and load charts
- ▶ Easy-to-install optional 24' (7.31 m) one stage or 24-40' (7.31-12.19 m) two stage telescoping jib, man baskets or work platform increase job capacities
- ▶ Electronic Load Moment Indicator and anti-two-block device standard
- ▶ Externally located planetary rotation drive for easy accessibility for maintenance
- ▶ 2-speed planetary winch has 10,500 lb (4 703 kg) maximum permissible 1 part line, 37,000 lb (16 782 kg) breaking strength, 186 ft/min (57 m/min) maximum line speed
- ▶ Dual control station with direct mechanically controlled hydraulic system
- ▶ 70 gal (266 L) capacity hydraulic tank

BT MODEL

LOAD RATINGS



CAUTION Do not use this specification sheet as a load rating chart. The format of data is not consistent with the machine chart and may be subject to change.

BOOM LENGTH Maximum Load Chart in pounds (lbs) with fully extended outrigger

OPERATING RADIUS (FT)	27 FT		34 FT		43 FT		52 FT		61 FT		70 FT	
	LOADED BOOM ANGLE (DEG)	LOAD RATING (LB)	LOADED BOOM ANGLE (DEG)	LOAD RATING (LB)	LOADED BOOM ANGLE (DEG)	LOAD RATING (LB)	LOADED BOOM ANGLE (DEG)	LOAD RATING (LB)	LOADED BOOM ANGLE (DEG)	LOAD RATING (LB)	LOADED BOOM ANGLE (DEG)	LOAD RATING (LB)
5	77	34,000*										
10	66	21,100*	71	17,100*	75	16,000*	78	15,700*				
15	54	15,100*	62	14,000*	68	12,100*	72	11,100*	75	10,800*	77	9,600*
20	39	11,100*	51	10,100*	61	9,100*	66	8,600*	71	8,200*	73	7,300*
25	17	7,900*	40	7,700*	53	7,100*	61	6,900*	66	6,600*	69	5,900*
30			23	6,500*	44	6,100*	54	5,600*	60	5,300*	64	4,900*
35					33	4,800*	47	4,700*	54	4,600*	60	4,150*
40					16	3,500*	38	4,100*	48	3,900*	55	3,550*
45							27	3,250*	41	3,200*	49	3,050*
50							9	2,950*	33	2,800*	44	2,650*
55									23	2,500*	37	2,350*
60											29	1,900*
65											19	1,700*

NOTE: STRUCTURAL STRENGTH RATINGS IN CHART ARE INDICATED WITH AN ASTERISK *

AREA OF OPERATION

DO NOT OPERATE IN SHADED AREA WITHOUT OPTIONAL FRONT STABILIZER

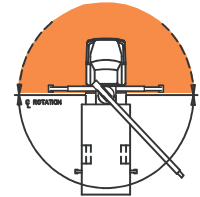

Deductions from rate loads for load handling devices BT

Overhaul Ball	125 lbs
1 Sheave Load Block	200 lbs
2 Sheave Load Block	230 lbs
Aux Sheave	50 lbs

STOWED JIB DEDUCTIONS (POUNDS)

	450	360	260	230	200	175
--	-----	-----	-----	-----	-----	-----

JIB CAPACITIES FOR ALL BOOM LENGTHS VERIFY OPERATIONAL MODE SETTING ON LMI DISPLAY BEFORE LIFTING WITH JIB

Loaded Boom Angle	35°	40°	45°	50°	55°	60°	65°	70°	75°	80°
Retracted 24 ft Jib	700	825	1,000	1,150	1,340	1,600	1,900	2,300	3,100	4,160
Extended 40 ft Jib	520	580	650	730	810	930	1,080	1,400	1,810	2,260

RANGE DIAGRAM (27 - 70 FT BOOM)

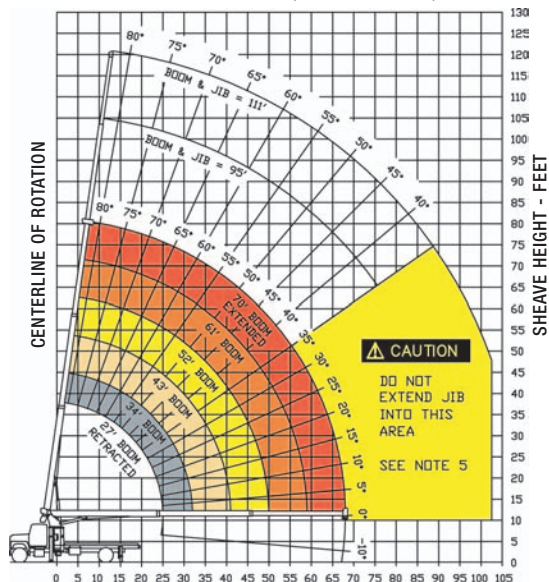

GENERAL NOTES

- The operator must read and understand the Owner's Manual before operating this crane.
- Positioning or operation of crane beyond areas shown on this chart is not intended or approved except where specified in Owner's Manual.
- Loaded boom angles at specified boom lengths give only an approximation of the operating radius. The boom angle before loading should be greater to account for deflections. Do not exceed the operating radius for rated loads.
- Use rating of next longer boom for boom lengths not shown. Use rating of next greater radius for load radii not shown.
- Boom must be fully retracted when jib is erected before lowering below minimum angle. Retracted jib has no lifting capacity below a 50° boom angle.
- Use rating of next lower boom angle for boom angles not shown on jib load rating chart.
- Lifting off the main boom point while the swing around jib is erected is not intended or approved.
- Do not lower boom into this area, as hydraulic pressure will not allow raising the boom without retracting boom first.
- Crane load ratings on outriggers are based on freely suspended loads with the machine leveled and standing on a firm uniform supporting surface. No attempt shall be made to move a load horizontally on the ground in any direction.
- Practical working loads depend on supporting surface, wind and other factors affecting stability such as hazardous surroundings, experience of personnel, and proper handling, must all be taken into account by the operator.
- The maximum load which may be telescoped is limited by hydraulic pressure, boom angle, and boom lubrication. It is safe to attempt to telescope any load within the limits of the load rating chart.

INFORMATION

- Deductions must be made from rated loads for stowed jib, optional attachments, hooks and loadblocks (see deduction chart). Weights of slings and other load handling devices shall be considered a part of the load.
- Crane load ratings with outriggers are based on outriggers and stabilizers extended and set with all load removed from the carrier wheels.
- Load ratings do not exceed 85% of tipping load.

DEFINITIONS

- Operating radius is the horizontal distance from the axis of rotation to the center of the vertical hoist line or load hook with load suspended.
- Loaded boom angle as shown in the Load Ratings Chart is the included angle between the horizontal and longitudinal axes of the boom base after lifting rated load at rated radius.

RM MODEL

LOAD RATINGS



CAUTION Do not use this specification sheet as a load rating chart. The format of data is not consistent with the machine chart and may be subject to change.

BOOM LENGTH Maximum Load Chart in pounds (lbs) with fully extended outrigger

OPERATING RADIUS (FT)	27 FT		34 FT		43 FT		52 FT		61 FT		70 FT	
	LOADED BOOM ANGLE (DEG)	LOAD RATING (LB)	LOADED BOOM ANGLE (DEG)	LOAD RATING (LB)	LOADED BOOM ANGLE (DEG)	LOAD RATING (LB)	LOADED BOOM ANGLE (DEG)	LOAD RATING (LB)	LOADED BOOM ANGLE (DEG)	LOAD RATING (LB)	LOADED BOOM ANGLE (DEG)	LOAD RATING (LB)
5	77	34,000*										
10	66	21,100*	71	17,100*	75	16,000*	78	15,700*				
15	54	15,100*	62	14,000*	68	12,100*	72	11,100*	75	10,800*	77	9,600*
20	39	11,100*	51	10,100*	61	9,100*	66	8,600*	71	8,200*	73	7,300*
25	17	7,900*	40	7,700*	53	7,100*	61	6,900*	66	6,600*	69	5,900*
30			23	6,500*	44	6,100*	54	5,600*	60	5,300*	64	4,900*
35					33	4,800*	47	4,700*	54	4,600*	60	4,150*
40					16	3,500*	38	4,100*	48	3,900*	55	3,550*
45							27	3,250*	41	3,200*	49	3,050*
50							9	2,950*	33	2,800*	44	2,650*
55									23	2,500*	37	2,350*
60											29	1,900*
65											19	1,700*

NOTE: STRUCTURAL STRENGTH RATINGS IN CHART ARE INDICATED WITH AN ASTERISK *

AREA OF OPERATION

360° Full Capacity
Area of Operation

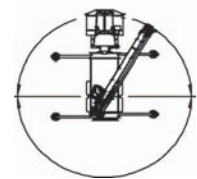

Deductions from rate loads for load handling devices RM

Overhaul Ball	125 lbs
1 Sheave Load Block	200 lbs
2 Sheave Load Block	230 lbs

STOWED JIB DEDUCTIONS (POUNDS)						
	450	360	260	230	200	175

JIB CAPACITIES FOR ALL BOOM LENGTHS VERIFY OPERATIONAL MODE SETTING ON LMI DISPLAY BEFORE LIFTING WITH JIB

Loaded Boom Angle	35°	40°	45°	50°	55°	60°	65°	70°	75°	80°
Retracted 24 ft Jib	700	825	1,000	1,150	1,340	1,600	1,900	2,300	3,100	4,160
Extended 40 ft Jib	520	580	650	730	810	930	1,080	1,400	1,810	2,260

RANGE DIAGRAM (27 - 70 FT BOOM)

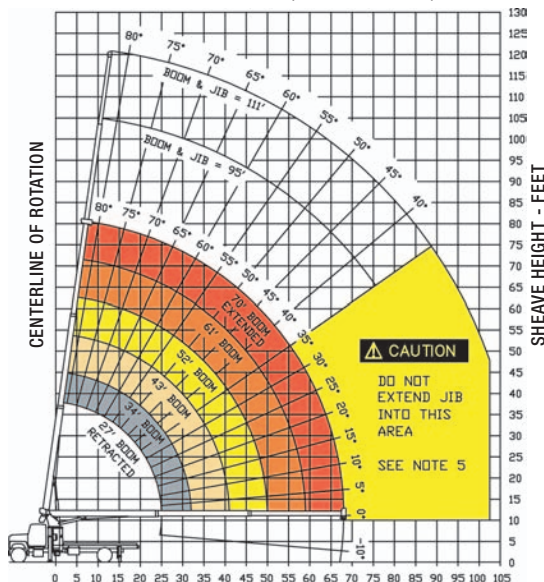

GENERAL NOTES

- The operator must read and understand the Owner's Manual before operating this crane.
- Positioning or operation of crane beyond areas shown on this chart is not intended or approved except where specified in Owner's Manual.
- Loaded boom angles at specified boom lengths give only an approximation of the operating radius. The boom angle before loading should be greater to account for deflections. Do not exceed the operating radius for rated loads.
- Use rating of next longer boom for boom lengths not shown. Use rating of next greater radius for load radii not shown.
- Boom must be fully retracted when jib is erected before lowering below minimum angle. Retracted jib has no lifting capacity below a 50° boom angle.
- Use rating of next lower boom angle for boom angles not shown on jib load rating chart.
- Lifting off the main boom point while the swing around jib is erected is not intended or approved.
- Do not lower boom into this area, as hydraulic pressure will not allow raising the boom without retracting boom first.
- Crane load ratings on outriggers are based on freely suspended loads with the machine leveled and standing on a firm uniform supporting surface. No attempt shall be made to move a load horizontally on the ground in any direction.
- Practical working loads depend on supporting surface, wind and other factors affecting stability such as hazardous surroundings, experience of personnel, and proper handling, must all be taken into account by the operator.
- The maximum load which may be telescoped is limited by hydraulic pressure, boom angle, and boom lubrication. It is safe to attempt to telescope any load within the limits of the load rating chart.

INFORMATION

- Deductions must be made from rated loads for stowed jib, optional attachments, hooks and loadblocks (see deduction chart). Weights of slings and other load handling devices shall be considered a part of the load.
- Crane load ratings with outriggers are based on outriggers and stabilizers extended and set with all load removed from the carrier wheels.
- Load ratings do not exceed 85% of tipping load.

DEFINITIONS

- Operating radius is the horizontal distance from the axis of rotation to the center of the vertical hoist line or load hook with load suspended.
- Loaded boom angle as shown in the Load Ratings Chart is the included angle between the horizontal and longitudinal axes of the boom base after lifting rated load at rated radius.



BOOM TRUCK CRANE STINGER 3470

BT MODEL

WINCH DATA						
		1 Part Line	2 Part Line	3 Part Line	4 Part Line	
Winch	Cable Supplied	Lift and Max Speed	Lift and Max Speed	Lift and Max Speed	Lift and Max Speed	
Standard Stationary Winch	9/16" Diam IWRC XXIP	10,500 lb 186 fpm	21,000 lb 93 fpm	31,500 lb 62 fpm	34,000 lb 45.5 fpm	
	9/16" Diam Rotation Resistant	6,720 lb 186 fpm	13,440 lb 93 fpm	20,160 lb 56.7 fpm	26,880 lb 45.5 fpm	

BLOCK TYPE	
Overhaul Ball	6.25 ton (5.7 mt)
1 Sheave Block	17.5 ton (15.9 mt)

CAUTION ⚠️

Overload and anti-two-block systems must be in good operating condition before operating crane. Refer to Owners Manual.

Keep at least 3 wraps of loadline on drum at all times.

Use only 9/16" diameter cable with 37,000 lb. breaking strength on this machine.

2 MOUNTING CONFIGURATIONS

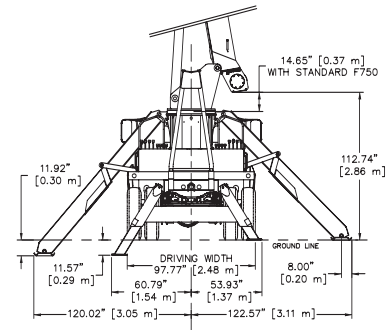
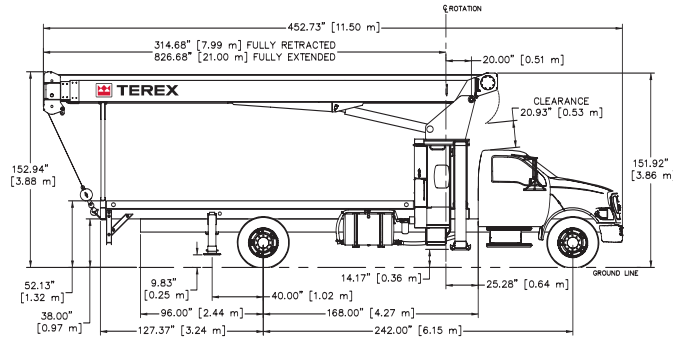

CARRIER PROVIDED BY TEREX

STINGER BT3470 - Behind Cab Mounting Configuration	
Manufacturer	Ford F-750 4 x 2 Chassis
Standard Engine	Caterpillar C-7 7.2 L I-6
Standard Horsepower	210 hp @ 2,500 rpm
Standard Torque	605 lb. Ft. @ 1,440 rpm
Full Tank Capacity	45 gal (170 L)
Standard Transmission	Spicer ES066-7B
Speed Standard Transmission	Manual 7-speed
Max Speed Standard Transmission	74 mph (118.4 km/h)
Max Gradeability	17.7% in 1st
Standard Transmission	15.8% in Rev
Optional Transmission	Allison
Speed Optional Transmission	Automatic 5-speed
Max Speed Optional Transmission	74 mph (118.4 km/h)
Max Gradeability	21.1% in 1st
Optional Transmission	30.5% in Rev
Gross Vehicle Weight Rating	33,000 lb (14 969 kg)
Front Axle Weight Rating	12,000 lb (5 443 kg)
Rear Axle Weight Rating	21,000 lb (9 525 kg)
Front Tires	22.5" x 8.5" 11R22.5 G Goodyear G159
Rear Tires	22.5" x 7.5" 11R22.5 G Goodyear G167A
Brakes	Air, Hydraulic Anti-Lock System
Exhaust Position	Horizontal Left Side

INCLUDED OPTIONS

- ▶ Fuel tank (45 gal)-175 L
- ▶ Power Steering
- ▶ Electric Horn
- ▶ Factory A/C
- ▶ Power Port (Cigar lighter)
- ▶ AM/FM Radio w/ Clock
- ▶ Dual West Coast Stainless Rear View Mirrors
- ▶ Standard Factory Warranty

CHASSIS RECOMMENDATIONS

STINGER BT3470 - Behind Cab Mounting Configuration	
Combined Axle Weight Rating	33,000 lb (14 969 kg)
Front Axle Weight Rating	12,000 lb (5 443 kg)
Rear Axle Weight Rating	21,000 lb (9 525 kg)
Wheel base	242" (6.15 m)
Cab to Axle	168" (4.27 m)
Afterframe	96" (2.44 m)
Frame Section Modulus	16.98 in ³ (278 cm ³)
RBM per Frame Rail	1,400,000 in/lb (16 130 kg/m)
Frame Height (Unloaded)	40" (7.62 m)
Exhaust Position	Horizontal Left Side

RM MODEL
WINCH DATA

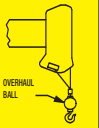
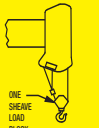
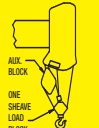
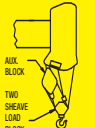
Winch	Cable Supplied	1 Part Line	2 Part Line	3 Part Line	4 Part Line
					
		Lift and Max Speed	Lift and Max Speed	Lift and Max Speed	Lift and Max Speed
Standard Stationary Winch	9/16" Diam IWRC XXIP	10,500 lb 186 fpm	21,000 lb 93 fpm	31,500 lb 62 fpm	34,000 lb 45.5 fpm
	9/16" Diam Rotation Resistant	6,720 lb 186 fpm	13,440 lb 93 fpm	20,160 lb 56.7 fpm	26,880 lb 45.5 fpm

BLOCK TYPE

Overhaul Ball	6.25 ton (5.7 mt)
1 Sheave Block	17.5 ton (15.9 mt)

CAUTION

Overload and anti-two-block systems must be in good operating condition before operating crane. Refer to Owners Manual.

Keep at least 3 wraps of loadline on drum at all times.

Use only 9/16" diameter cable with 33,600 lb. breaking strength on this machine.

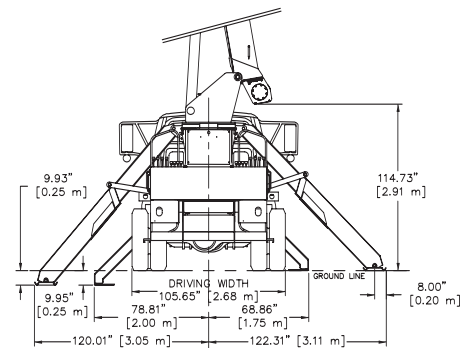
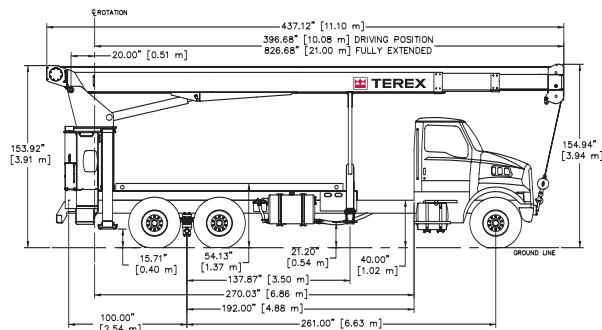
2 MOUNTING CONFIGURATIONS

CARRIER PROVIDED BY TEREX
STINGER RM3470 – Rear Mount Configuration

▶ Manufacturer	Sterling LT7501 6 x 4 (60 000)
▶ Standard Engine	Caterpillar C-7 7.2 L I-6
▶ Standard Horsepower	300 hp @ 1,440 rpm
▶ Standard Torque	860 lb. Ft. @ 1,500 rpm
▶ Full Tank Capacity	120 gal (454 L)
▶ Standard Transmission	Eaton Fuller RT-8908LL
▶ Speed Standard Transmission	Manual 10-speed
▶ Max Speed Standard Transmission	74 mph (120 km/h)
▶ Max Gradeability	54%
Standard Transmission	
▶ Optional Transmission	Allison
▶ Speed Optional Transmission	Automatic 6 speeds
▶ Max Speed Optional Transmission	74 mph (120 km/h)
▶ Max Gradeability	17%
Optional Transmission	
▶ Gross Vehicle Weight (without crane)	60,000 lb (27 210 kg)
▶ Front Axle Weight Rating (without crane)	20,000lb (9 067kg)
▶ Rear Axle Weight Rating (without crane)	40,000 lb (18 144 kg)
▶ Front Tires	425/65R 22.5 Michelin XZY (20 ply)
▶ Rear Tires	11R 22.5 Michelin XDE M/S (14 ply)
▶ Brakes	Air, Hydraulic Anti-Lock System
▶ Exhaust Position	Horizontal Left Side

INCLUDED OPTIONS

- ▶ Dual Fuel Tanks (120 gal-454 L)
- ▶ Power Steering
- ▶ Electric Horn
- ▶ Factory A/C
- ▶ Power Port (Cigar lighter)
- ▶ AM/FM Radio w/ Clock
- ▶ Dual West Coast Stainless Rear View Mirrors
- ▶ Standard Factory Warranty

CHASSIS RECOMMENDATIONS
STINGER RM3470 – Rear Mount Configuration

- | | |
|-------------------------------|---|
| ▶ Combined Axle Weight Rating | 60,000 lb (27 210 kg) |
| ▶ Front Axle Weight Rating | 20,000 lb (9 067 kg) |
| ▶ Rear Axle Weight Rating | 40,000 lb (18 144 kg) |
| ▶ Wheel Base | 261" (6.62 m) |
| ▶ Cab to Axle | 192" (4.87 m) |
| ▶ Afterframe | 114" (2.89 m) |
| ▶ Frame Section Modulus | 30.00 in ³ (4.91 cm ³) |
| ▶ RBM per Frame Rail | 1,800,000 in/lb (16 130 kg/m) |
| ▶ Frame Height (Unloaded) | 40" (7.62 m) |
| ▶ Exhaust Position | Horizontal Left Side |

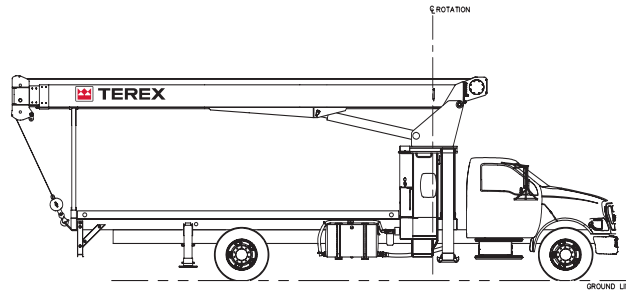
BT MODEL
SPECIFICATIONS

BOOM

- ▶ 27-70' (82.30-21.34 m) three-section full power fully synchronized boom. Patented keel boom design utilizes a keel shaped base plate combined with a deep, four plate boom section to optimize strength / rigidity-to-height ratio. Exclusive, patented color-coded boom and load charts allow the operator to easily determine boom extension, boom angle and load capacity. Maximum tip height with three-section 27-70' (82.30-21.34 m) boom is 80' (24.38 m). Maximum tip height with optional two-stage 24-40' (7.31-12.19 m) jib is 120' (36.57 m).

WINCH

- ▶ Hydraulic winch with gear motor and planetary reduction gearing provides 2-speed operation. First layer rope pull is 11,400 lb (5 170 kg). Wire rope size is 9/16" (14 mm) with 37,000 lb (16 782 kg) breaking strength.

OPERATING SPEEDS

- ▶ Mainframe / turret assembly planetary gear rotation provides 180° rotation (370° with optional front bumper outrigger). Swing rotation is 55 seconds. Boom up/down is 25/16 seconds and boom extend/retract is 61/29 seconds.

HYDRAULICS

- ▶ Three-section pump allows the operator to perform simultaneous crane operations (winch, boom and swing). Capacities are 32, 17 and 8 gpm (122, 64 and 30 L/m). Hydraulic tank capacity is 70 gal (265 L).

CONTROLS

- ▶ Fully proportional, excellent metering characteristics for precise boom movements. Independent outrigger controls allow the crane to be stable and level in rigorous working conditions. Load Moment Indication System has audio alarm and functional shut down when operator encounters an overload situation.

OUTRIGGERS

- ▶ Front outriggers are Link-Type. The maximum width over main outrigger pad is 20' 5" (6.23 m), main outrigger spread at maximum ground penetration is 20' (6.10 m).
- ▶ Rear outriggers are A-Frame type. The maximum width over auxiliary outrigger pads is 10' 2" (3.09 m).

SUBFRAME

- ▶ Single fabricated, closed-box style subframe yields greater strength and rigidity. Wheelbase for standard truck crane mounting configuration is 242" (6.15 m).

OPTIONS AND ACCESSORIES

- ▶ Single and two-stage jibs
- ▶ Multi-part load blocks
- ▶ Main winch with 2 speed motor
- ▶ Auxiliary winch
- ▶ Rotation-resistant load line
- ▶ Heavy duty wood flatbeds
- ▶ Extra heavy duty wood flatbeds
- ▶ Extra heavy duty steel flatbeds
- ▶ Radio remote controls
- ▶ One-man or two-man baskets
- ▶ Self-leveling work platform
- ▶ Winch drum tensioner
- ▶ Continuous rotation
- ▶ Oil cooler
- ▶ Single front bumper outrigger (required for 370° or continuous rotation)
- ▶ Hydraulic hose reel
- ▶ Hydraulic auxiliary tool circuit
- ▶ Tool Box

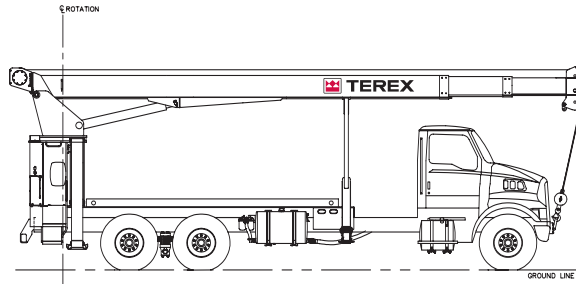
RM MODEL
SPECIFICATIONS

BOOM

- ▶ 27-70' (82.30-21.34 m) three-section full power fully synchronized boom. Patented keel boom design utilizes a keel shaped base plate combined with a deep, four plate boom section to optimize strength / rigidity-to-height ratio. Exclusive, patented color-coded boom and load charts allow the operator to easily determine boom extension, boom angle and load capacity. Maximum tip height with three-section 27-70' (82.30-21.34 m) boom is 80' (24.38 m). Maximum tip height with optional two-stage 24-40' (7.31-12.19 m) jib is 120' (36.57 m).

WINCH

- ▶ Hydraulic winch with gear motor and planetary reduction gearing provides 2-speed operation. First layer rope pull is 11,400 lb (5 170 kg). Wire rope size is 9/16" (14 mm) with 33,600 lb (15 240 kg) breaking strength.

OPERATING SPEEDS

- ▶ Mainframe / turret assembly planetary gear rotation provides 180° rotation (370° with optional front bumper outrigger). Swing rotation is 55 seconds. Boom up/down is 25/16 seconds and boom extend/retract is 61/29 seconds.

HYDRAULICS

- ▶ Three-section pump allows the operator to perform simultaneous crane operations (winch, boom and swing). Capacities are 32, 17 and 8 gpm (122, 64 and 30 L/m). Hydraulic tank capacity is 70 gal (265 L).

CONTROLS

- ▶ Fully proportional, excellent metering characteristics for precise boom movements. Independent outrigger controls allow the crane to be stable and level in rigorous working conditions. Load Moment Indication System has audio alarm and functional shut down when operator encounters an overload situation.

OUTRIGGERS

- ▶ Rear outriggers are Link-Type. The maximum width over main outrigger pad is 20' 5" (6.23 m), main outrigger spread at maximum ground penetration is 20' (6.10 m).
- ▶ Front outriggers are Out and Down type. The maximum width over auxiliary outrigger pads is 17' 6" (5.34 m).

SUBFRAME

- ▶ Single fabricated, closed-box style subframe yields greater strength and rigidity. Wheelbase for standard truck crane mounting configuration is 261" (6.63 m).

OPTIONS AND ACCESSORIES

- ▶ Single and two-stage jibs
- ▶ Multi-part load blocks
- ▶ Main winch with 2 speed motor
- ▶ Auxiliary winch
- ▶ Rotation-resistant load line
- ▶ Heavy duty wood flatbeds
- ▶ Extra heavy duty wood flatbeds
- ▶ Extra heavy duty steel flatbeds
- ▶ Radio remote controls
- ▶ One-man or two-man baskets
- ▶ Self-leveling work platform
- ▶ Winch drum tensioner
- ▶ Continuous rotation
- ▶ Oil cooler
- ▶ Single front bumper outrigger (required for 370° or continuous rotation)
- ▶ Hydraulic hose reel
- ▶ Hydraulic auxiliary tool circuit
- ▶ Tool Box



TEREX

STINGER 3470 | Contacts

SALES

Tom Limbach

Sales Director, Terex Cranes
Office: (319) 352-9357
Mobile: (815) 703-3905
Office Fax: (319) 352-9395
Email: tom.limbach@terexwaverly.com

Diane Sheedy

Director of International Sales
Office: (319) 352-9326
Office Fax: (319) 352-9395
Email: diane.sheedy@terexwaverly.com

Bruce Kramer

Sales Manager, Terex Cranes
Office: (319) 352-9347
Mobile: (815) 703-3896
Office Fax: (319) 352-9395
Email: bruce.kramer@terexwaverly.com

Chad Brandenburg

Sales Coordinator, Terex Cranes
Office: (319) 352-9356
Mobile: (910) 367-3152
Office Fax: (319) 352-9395
Email: chad.brandenburg@terexwaverly.com

Angie Scribner

Sales Assistant, Terex Cranes
Office: (319) 352-9309
Office Fax: (319) 352-9395
Email: angie.scribner@terexwaverly.com

SERVICE – PARTS

Roger Jones

Service Manager – Product Support
Office: (910) 395-8504
Mobile: (910) 367-6260
Office Fax: (910) 395-8538
Email: rjones@american-crane.com

Dino Nelson

Service Training Specialist
Office: (319) 352-9338
Mobile: (815) 703-1800
Office Fax: (319) 352-9378
Email: dino.nelson@terexwaverly.com

Fred Backer (Boom Trucks)

Service Technician
Office: (319) 352-9388
Mobile: (815) 703-6514
Office Fax: (319) 352-9378
Email: fred.backer@terexwaverly.com

Dan Kalkbrenner (RT & T Cranes)

Service Manager – Product Support
Office: (319) 352-9368
Mobile: (815) 703-3900
Office Fax: (319) 352-9378
Email: dan.kalkbrenner@terexwaverly.com

Jim Dawson (RT & T Cranes)

Service Manager – Product Support
Office: (319) 352-9366
Mobile: (815) 703-3899
Office Fax: (319) 352-9378
Email: jim.dawson@terexwaverly.com

PARTS

Peggy Pellican

Director of Aftermarket Sales
Office: (336) 644-0536
Mobile: (336) 442-8348
Office Fax: (336) 644-0495
Fax: (801) 991-8193
Email: ppellican@terexparts.com

QUALITY ASSURANCE

Lee Linderkamp

Quality Assurance Manager
Office: (319) 352-9364
Mobile: (815) 703-3898
Office Fax: (319) 352-9378
Email: lee.linderkamp@terexwaverly.com

Clint Schrage

Warranty Manager
Office: (319) 352-9305
Office Fax: (319) 352-9378
Email: clint.schrage@terexwaverly.com

ENGINEERING

George Green

Director of Engineering
Office: (319) 352-9315
Office Fax: (319) 352-9378
Email: george.green@terexwaverly.com

Dave Schoonover (Boom Trucks)

Project Engineer
Office: (319) 352-9372
Office Fax: (319) 352-9378
Email: dave.schoonover@terexwaverly.com

Brian Thomas (RT Cranes)

Project Engineer
Office: (319) 352-9386
Office Fax: (319) 352-9378
Email: brian.thomas@terexwaverly.com

Dave Frerking (T Cranes)

Project Engineer
Office: (319) 352-9321
Office Fax: (319) 352-9378
Email: dave.frerking@terexwaverly.com

MANAGEMENT

Dan Micheau

Operations Manager, Terex Cranes
Office: (319) 352-9314
Mobile: (815) 703 3903
Office Fax: (319) 352-5727
Email: dan.micheau@terexwaverly.com

TEREX Cranes
106-12th Street S.E.
Waverly, IA 50677-9466 USA

TEL (319) 352-3920
FAX (319) 352-5727
EMAIL inquire@terexwaverly.com
WEB terex.com